

1. ALL PIPES SHALL BE CONSTRUCTED TO BE FLUSH WITH THE INSIDE WALLS.
2. CONTRACTOR IS RESPONSIBLE FOR PROVIDING ALL PIPING, INCLUDING PIPES BETWEEN VAULTS.

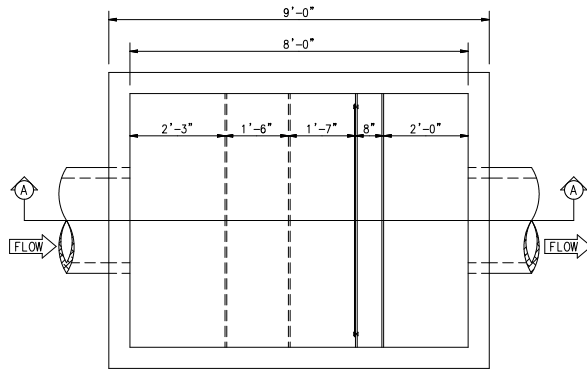

TOP VIEW (INTERNAL)

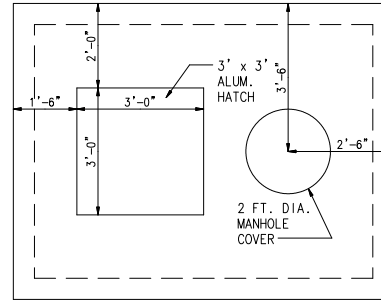

TOP VIEW (SLAB)

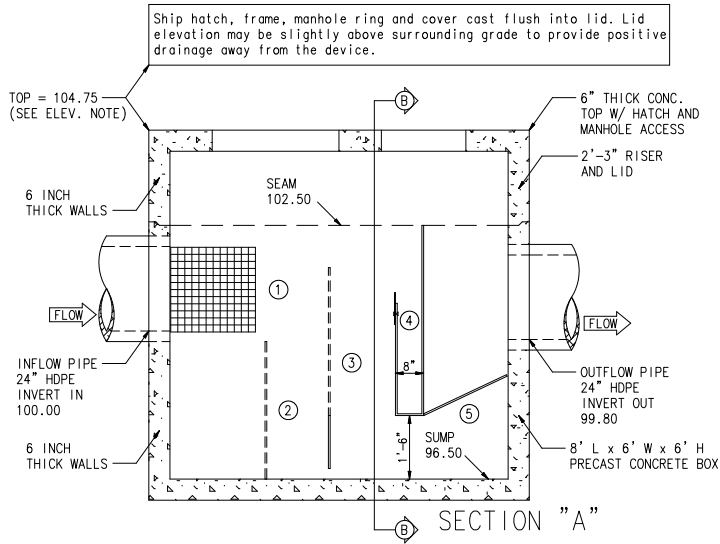

SECTION "A"

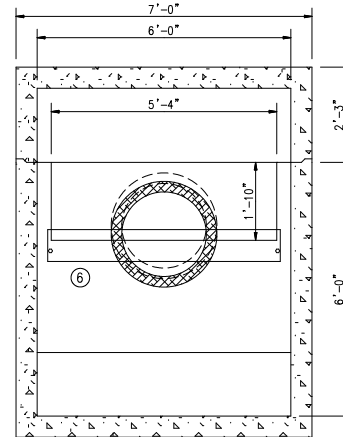

SECTION B

LEGEND

- ① EXPANDED ALUMINUM BASKET W/ 1/4" MESH LINING, 2'-0" H x 2'-0" L x 6'-0" W
- ② 1ST INTERNAL BAFFLE W/ 1" HOLES DRILLED AT 1-1/4" O.C., 3'-3" H.
- ③ 2ND INTERNAL BAFFLE W/ 1" HOLES DRILLED AT 1 1/4" O.C., 5'-0" H.
- ④ SPILL PROTECTION RESERVOIR 4'-6" H. WITH A 1'-10" FRONT CUT.
- ⑤ 3/4" COCONUT FIBER FILTER IN ALUMINUM FRAME 2'-2" LONG.
- ⑥ 1/4" ALUMINUM PLATE, 9" H., 5'-6" WIDE.

CRYSTALSTREAM "CRYSTALCLEAN" WATER QUALITY VAULT
MODEL "866"

Protected by U.S. Patent No's: 6,797,161; 6,936,163; 6,939,461; 6,951,607; 6,994,783; 7,011,743; 7,037,436

SPECIFICATIONS

1. TOTAL FLOW CAPACITY SHALL BE 13.5 CFS.
2. WATER QUALITY FLOW OF 2.26 CFS MUST BE TREATED WITH A HYDRAULIC LOADING RATE OF 22 GPM/SF OR LESS.
3. SPILL PROTECTION CAPACITY SHALL BE 783 GALLONS BEFORE OVERFLOW.
4. ANY CHANGES OR SUBSTITUTIONS MUST BE APPROVED BY THE ENGINEER AND THE REVIEWING AUTHORITY.



CrystalStream Technologies

THIS DRAWING IS COPYRIGHTED AND IS THE SOLE PROPERTY OF PRACTICAL BEST MANAGEMENT, INC. IT IS PROVIDED FOR THE EXCLUSIVE USE OF THE PROFESSIONAL ENGINEER NAMED HEREON. DESIGN IS BASED ON AND RELIES UPON DATA PROVIDED BY THE ENGINEER NAMED HEREON.

Sample Drawing
Model 866

Device No.: CST-1
GA0-866-081910

DESIGN FIRM: CrystalStream Technologies

JOB NAME:

eed-sample866 8/19/2010 p.a.d.s.