

1. ALL PIPES SHALL BE CONSTRUCTED TO BE FLUSH WITH THE INSIDE WALLS.
 2. CONTRACTOR IS RESPONSIBLE FOR PROVIDING ALL PIPING, INCLUDING PIPES BETWEEN VAULTS.

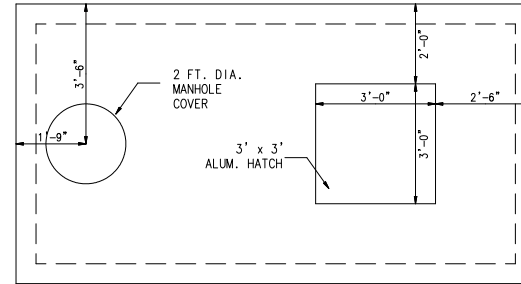

TOP VIEW (SLAB)

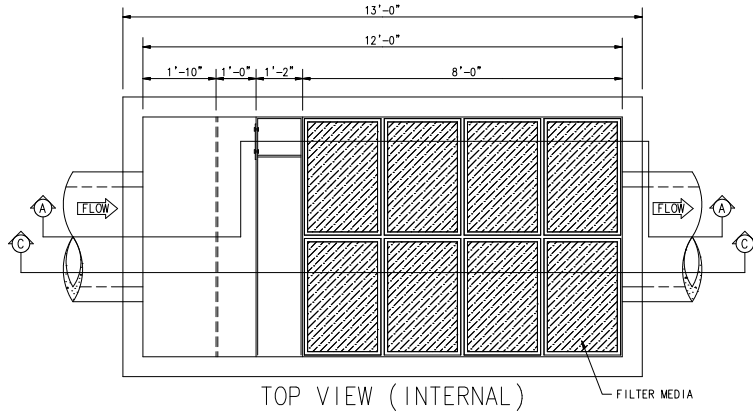
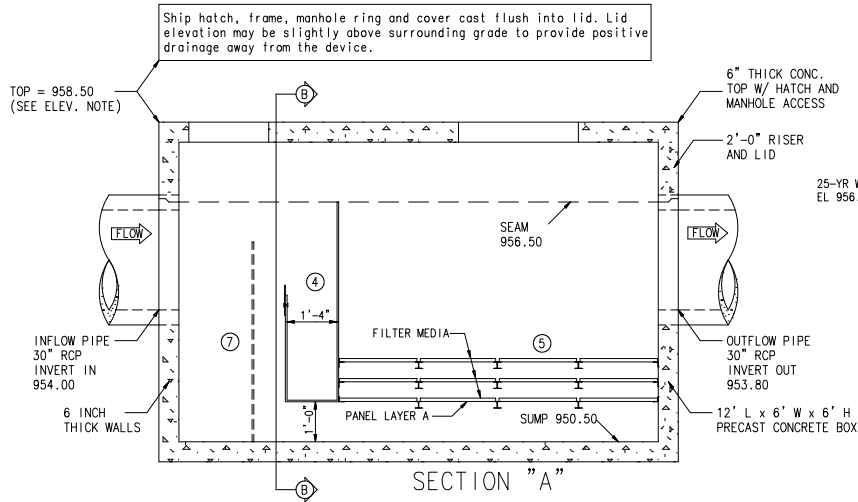

SECTION "A"

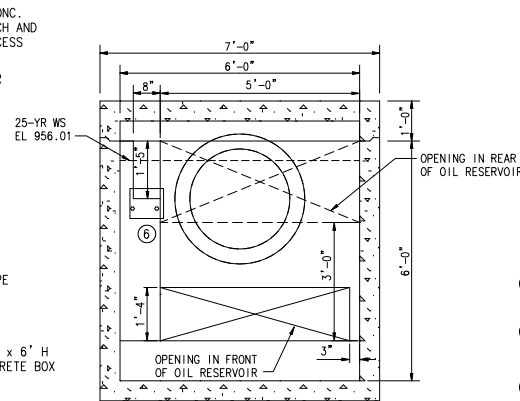

SECTION B

LEGEND

- ④ SPILL PROTECTION RESERVOIR 5'-0" H. WITH A 2'-4" FRONT CUT.
- ⑤ MEDIA FILTER ARRAY IN ALUMINUM FRAMES. NOMINALLY 2'-0" BY 3'-0", 8 PANELS PER LAYER FOR 3 LAYERS.
- ⑥ 1/4" ALUMINUM PLATE, 9" H., 10" WIDE.
- ⑦ 3RD INTERNAL BAFFLE W/ 1" HOLES DRILLED AT 1 1/4" O.C., 5'-0" H.

CRYSTALSTREAM "CRYSTALCOMPLETE" WATER QUALITY VAULT
 MODEL "2460HP"

(SHEET 2 of 3)

Protected by U.S. Patent No's: 6,797,161; 6,936,163; 6,939,461; 6,951,607; 6,994,783; 7,011,743, 7,037,436

eng-samp1e1260hp 4/20/2009 p.a.d.s.
 JOB NAME:

Sample 1260HP

Device No.: CST-1

DESIGN FIRM: Engineering Firm Name

SPECIFICATIONS

1. TOTAL FLOW CAPACITY SHALL BE 36 CFS.
2. WATER QUALITY FLOW OF 5.39 CFS MUST BE TREATED WITH A HYDRAULIC LOADING RATE OF 17 GPM/SF OR LESS.
3. SPILL PROTECTION CAPACITY SHALL BE 1,550 GALLONS BEFORE OVERFLOW.
4. ANY CHANGES OR SUBSTITUTIONS MUST BE APPROVED BY THE ENGINEER AND THE REVIEWING AUTHORITY.



CrystalStream Technologies

THIS DRAWING IS COPYRIGHTED AND IS THE SOLE PROPERTY OF PRACTICAL BEST MANAGEMENT, INC. IT IS PROVIDED FOR THE EXCLUSIVE USE OF THE PROFESSIONAL ENGINEER NAMED HEREON. DESIGN IS BASED ON AND RELIES UPON DATA PROVIDED BY THE ENGINEER NAMED HEREON.